

CITY OF MASON, TEXAS

WATER SYSTEM IMPROVEMENTS - PHASE 1

SHEET INDEX

1. *Title Sheet*
2. *General Notes*
3. *Overall Project Layout*
4. *Elevated Storage Tank Tie Ins*
5. *Plan & Profile STA 2+38 to STA 11+50*
6. *Plan & Profile STA 11+50 to STA 23+00*
7. *Plan & Profile STA 23+00 to STA 34+00*
8. *Plan & Profile STA 30+00 to STA 40+00*
9. *Plan & Profile STA 39+00 to STA 48+00*
10. *Plan & Profile STA 45+00 to STA 54+00*
11. *Plan & Profile STA 50+00 to STA 58+00*
12. *Standard Detail Sheet #1*
13. *Standard Detail Sheet #2*

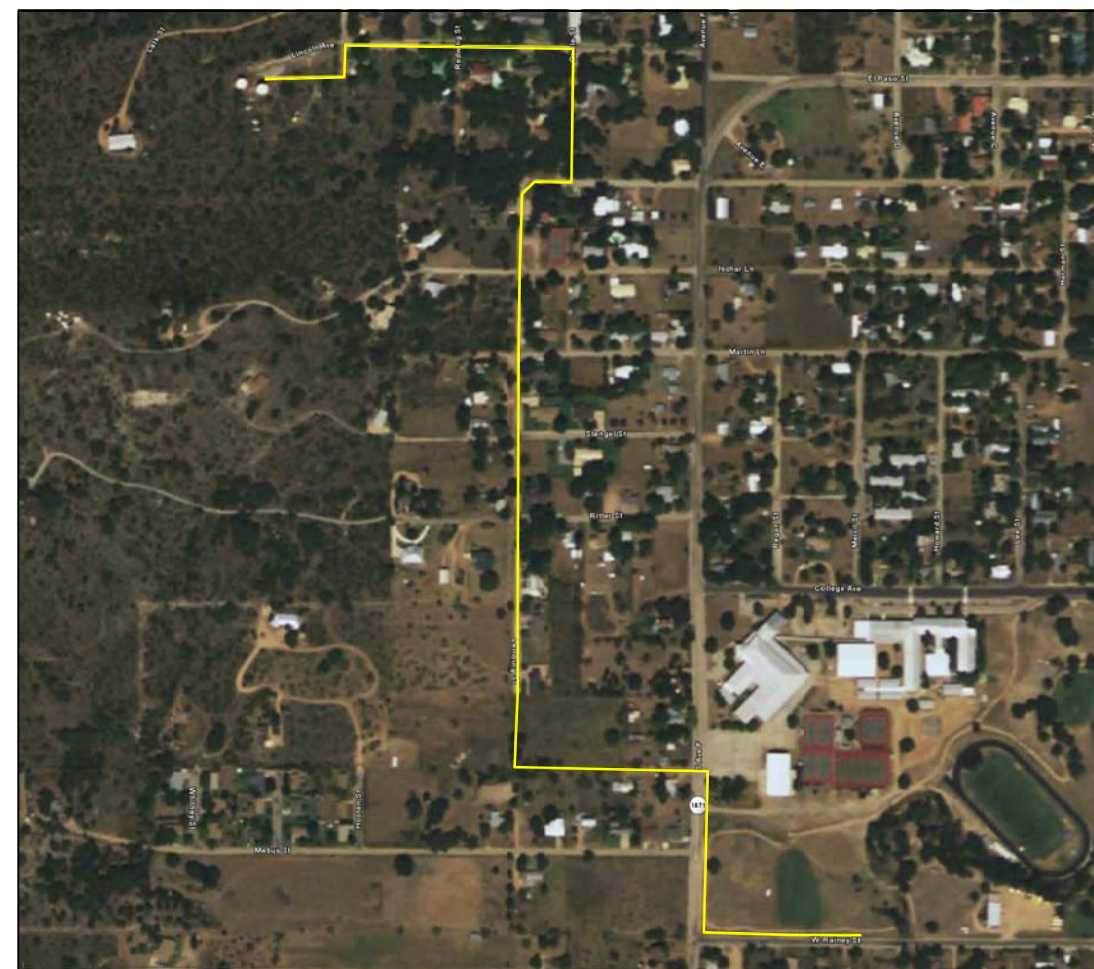

Vicinity Map
(Not to Scale)

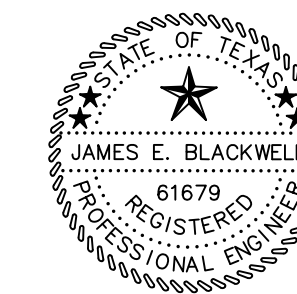

James Blackwell
JAMES E. BLACKWELL, P.E.

November 19, 2008

I, JAMES E. BLACKWELL, DO HEREBY CERTIFY THAT I AM A LICENSED PROFESSIONAL ENGINEER IN GOOD STANDING WITHIN THE STATE OF TEXAS, AND THAT THESE PLANS WERE PREPARED UNDER MY DIRECT SUPERVISION.



BLACKWELL ENVIRONMENTAL, LLC

1107 Highway 1431 - #113 - Marble Falls, Texas 78654
(512) 247-8700 Voice - (512) 56-8469 FAX

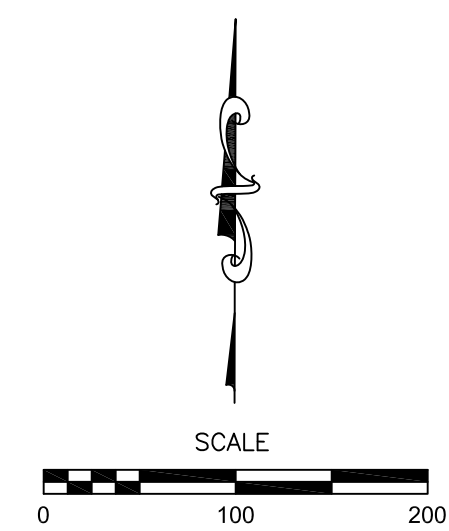
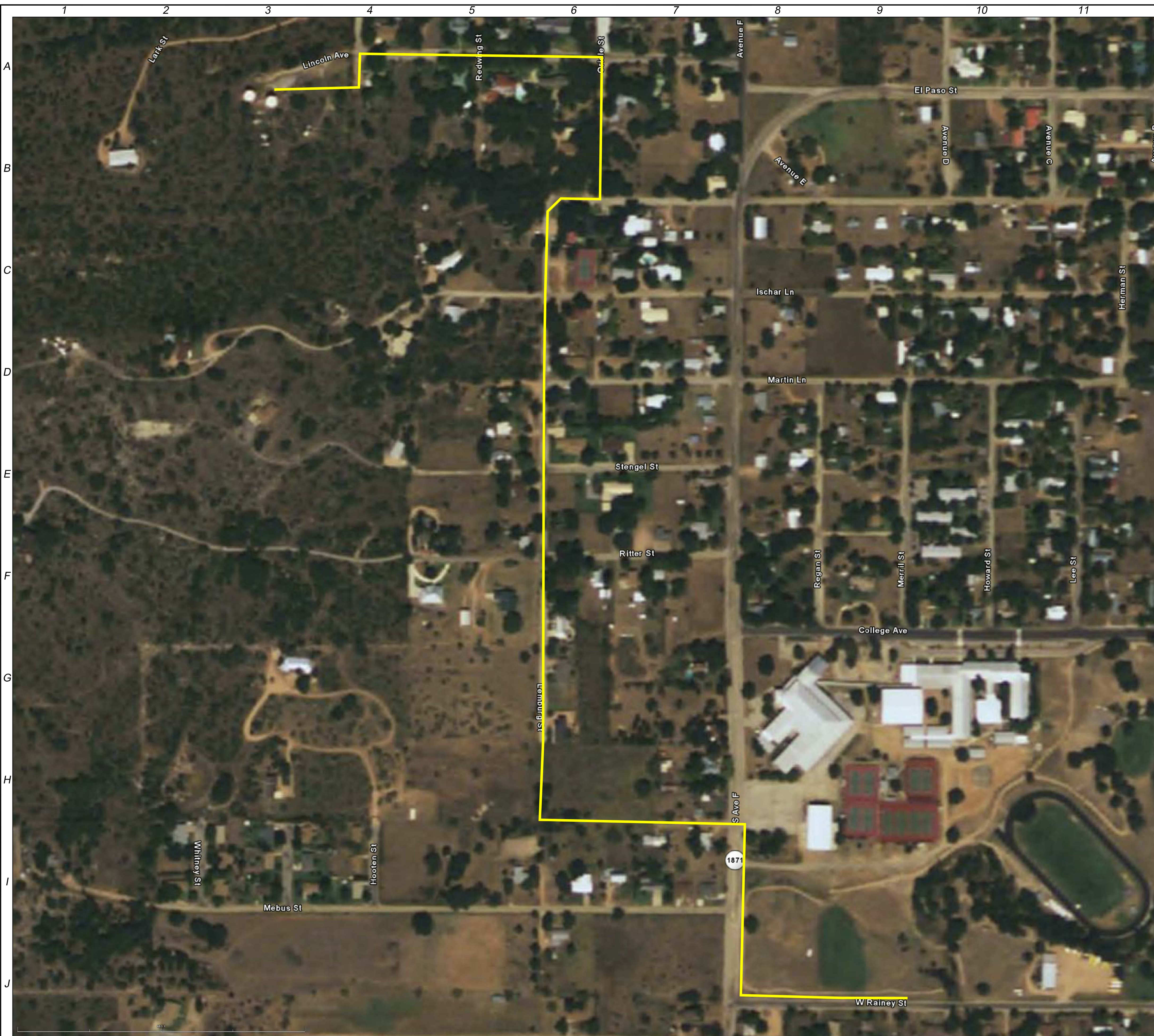

Scope of Work

The City of Mason, shall cause to be constructed water improvement related to their 10" Water Main Loop. Specifically, the scope of work for this project is as follows:

1. **10" Water Main Improvements** - Install approximately 5,800 linear feet of 10" SDR 26, Class 160 PVC Water Main to include trenching, bedding and backfill, complete in place.
2. **10" Mechanical Joint Gate Valve** - Install approximately 6 10" Mueller A-2360 MJ Gate Valves to include valve box, complete in place.
3. **8" Tapping Sleeve** - Install Three (3) 8" Tapping sleeve and box, complete in place.
4. **Horizontal Directional Drill** - Install approximately 160 lineal feet of 10" Ductile Iron Water Main by Directional Drilling, complete in place.
5. **Asphalt Replacement** - Install approximately 2,840 lineal feet of 2" Asphaltic concrete replacement, complete in place.
6. **Curb & Gutter** - Replace or Repair approximately 85 lineal feet of concrete curb & gutter, complete in place.
7. **Fire Hydrant Assembly** - Install approximately six (6) Mueller Super Centurion Fire Hydrant Assemblies, complete in place.
8. **Altitude Valve** - Install one (1) Altitude Valve to include vault, complete in place.
9. **Pressure Reducing Valve** - Install Two (2) Pressure reducing valves including vault, complete in place.

NO.	REVISIONS	BY	CHK.	DATE	APPR.

REFERENCE DRAWINGS	NOTES

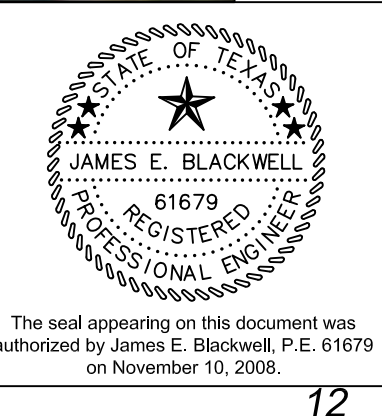

BLACKWELL ENVIRONMENTAL, LLC 1107 Highway 1431 - #113 - Marble Falls, Texas 78654 (512) 247-8700 Voice - (512) 56-8469 FAX			
DRAWN	CHECKED	APPROVED	
		BNC	OWNER
DATE	DATE		
11-10-08	11-10-08		

CITY OF MASON, TEXAS WATER SYSTEM IMPROVEMENTS - PHASE 1 PROPOSED 10" WATER LINE OVERALL LAYOUT & SCOPE OF WORK			
JOB NO.	DRAWING NO.		
			3 / 13

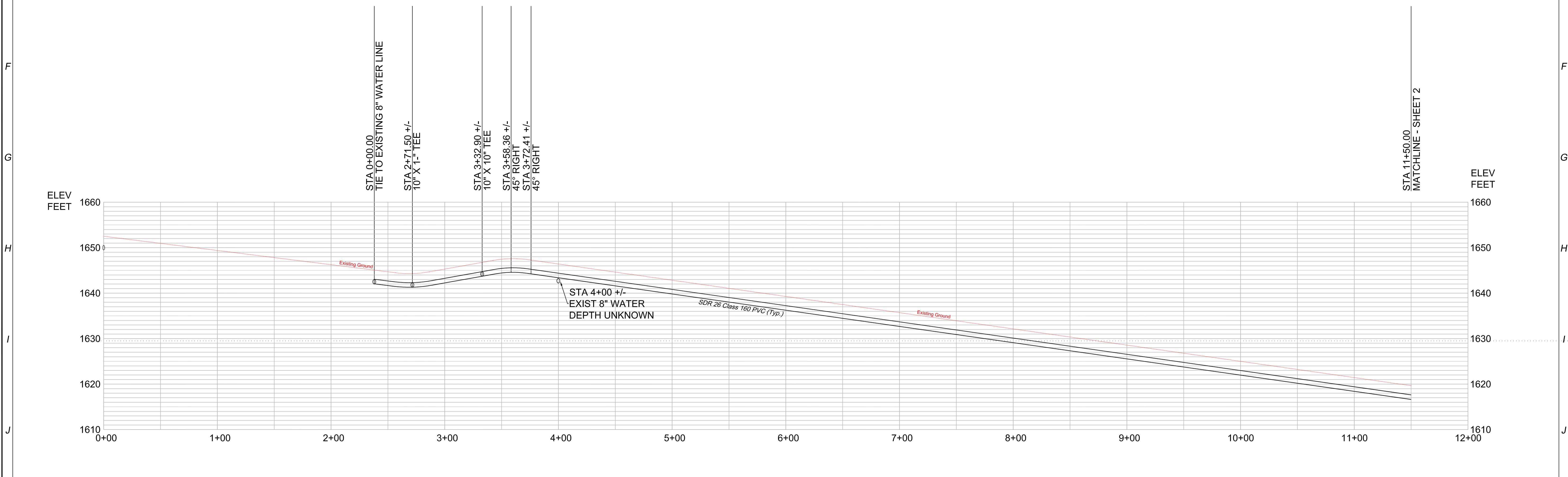
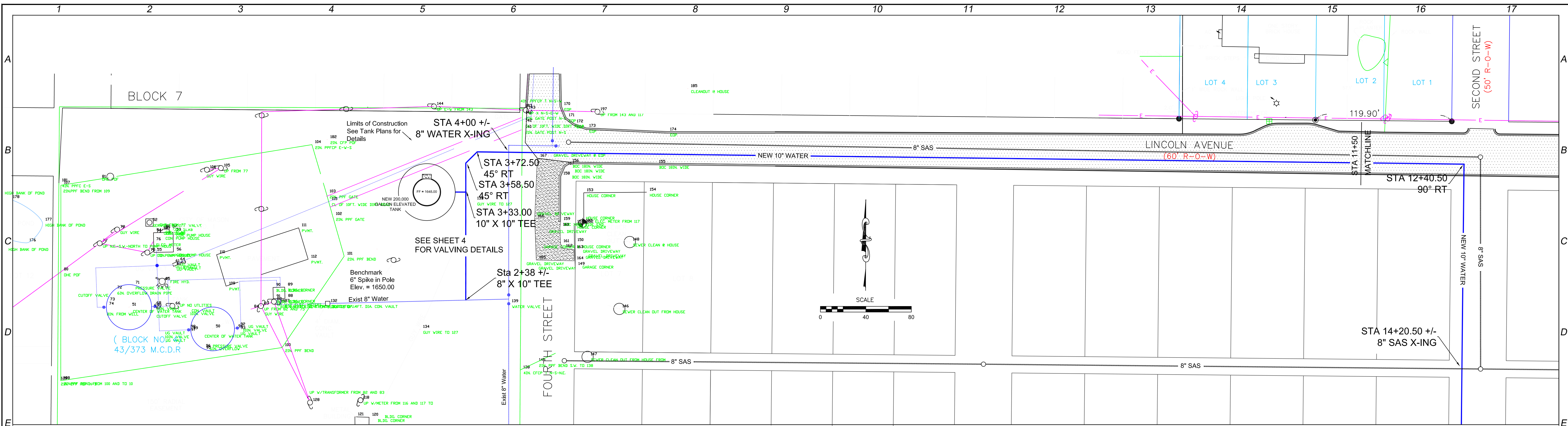

<p>REFERENCE DRAWINGS</p> <p>SCALE: HORIZ: 1" = 40' VERT: 1" = 10'</p>	<p>NOTES</p>	<table border="1" style="width:100%; border-collapse: collapse;"> <thead> <tr> <th>NO.</th> <th>REVISIONS</th> <th>BY</th> <th>CHK.</th> <th>DATE</th> <th>APPR.</th> </tr> </thead> <tbody> <tr><td> </td><td> </td><td> </td><td> </td><td> </td><td> </td></tr> <tr><td> </td><td> </td><td> </td><td> </td><td> </td><td> </td></tr> <tr><td> </td><td> </td><td> </td><td> </td><td> </td><td> </td></tr> <tr><td> </td><td> </td><td> </td><td> </td><td> </td><td> </td></tr> <tr><td> </td><td> </td><td> </td><td> </td><td> </td><td> </td></tr> <tr><td> </td><td> </td><td> </td><td> </td><td> </td><td> </td></tr> <tr><td> </td><td> </td><td> </td><td> </td><td> </td><td> </td></tr> <tr><td> </td><td> </td><td> </td><td> </td><td> </td><td> </td></tr> <tr><td> </td><td> </td><td> </td><td> </td><td> </td><td> </td></tr> <tr><td> </td><td> </td><td> </td><td> </td><td> </td><td> </td></tr> </tbody> </table>	NO.	REVISIONS	BY	CHK.	DATE	APPR.																																																														<p>BLACKWELL ENVIRONMENTAL, LLC 1107 Highway 1431 - #113 - Marble Falls, Texas 78654 (512) 247-8700 Voice - (512) 56-8489 FAX</p> <table border="1" style="width:100%; border-collapse: collapse;"> <tr> <td>DRAWN</td> <td>CHECKED</td> <td colspan="2">APPROVED</td> </tr> <tr> <td> </td> <td> </td> <td>BNC</td> <td>OWNER</td> </tr> <tr> <td>DATE</td> <td>DATE</td> <td colspan="2">SCALE</td> </tr> <tr> <td>11-10-08</td> <td>11-10-08</td> <td colspan="2"> </td> </tr> </table>	DRAWN	CHECKED	APPROVED				BNC	OWNER	DATE	DATE	SCALE		11-10-08	11-10-08			<p style="text-align: center;">CITY OF MASON, TEXAS WATER SYSTEM IMPROVEMENTS - PHASE 1 PROPOSED 10" WATER LINE P&P ALIGNMENT SHEET STA 2+38 TO 11+50</p> <p>JOB NO. DRAWING NO. 5 / 13</p>
NO.	REVISIONS	BY	CHK.	DATE	APPR.																																																																																		
DRAWN	CHECKED	APPROVED																																																																																					
		BNC	OWNER																																																																																				
DATE	DATE	SCALE																																																																																					
11-10-08	11-10-08																																																																																						

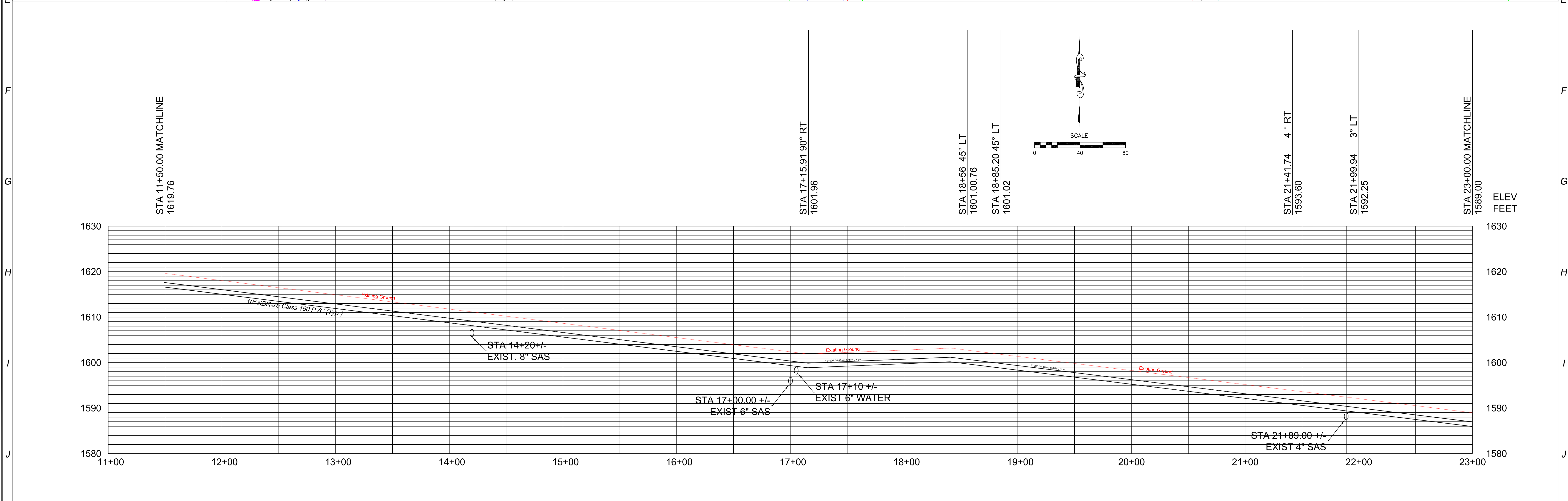
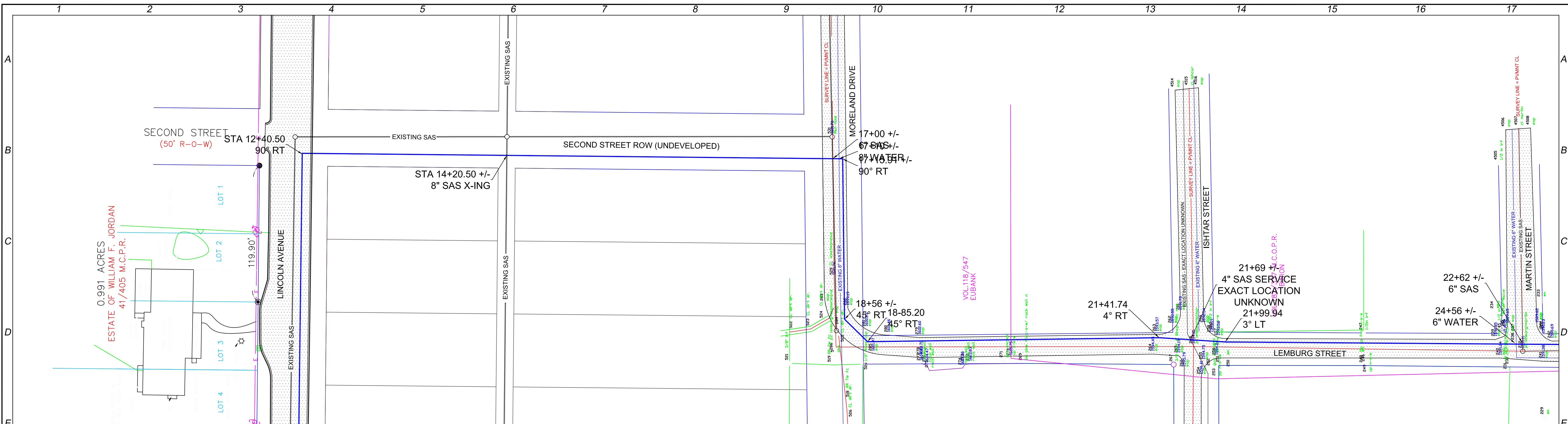

NO.	REVISIONS	BY	CHK.	DATE	APPR.

REFERENCE DRAWINGS

NOTES

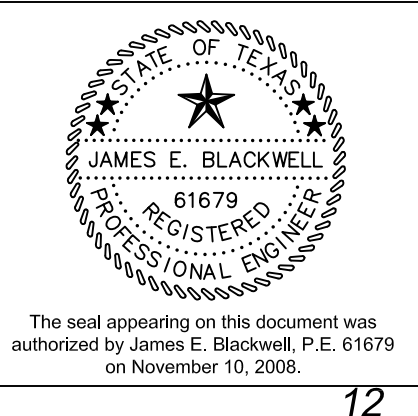

BLACKWELL ENVIRONMENTAL, LLC
 1107 Highway 1431 - #113 - Marble Falls, Texas 78654
 (512) 247-8700 Voice - (512) 56-8489 FAX

DRAWN	CHECKED	APPROVED
		BNC
		OWNER
DATE	DATE	SCALE
11-10-08	11-10-08	0 40 80

CITY OF MASON, TEXAS
 WATER SYSTEM IMPROVEMENTS - PHASE 1
 PROPOSED 10" WATER LINE
 P&P ALIGNMENT SHEET
 STA 11+50 to 23+00

JOB NO. DRAWING NO. 6/13

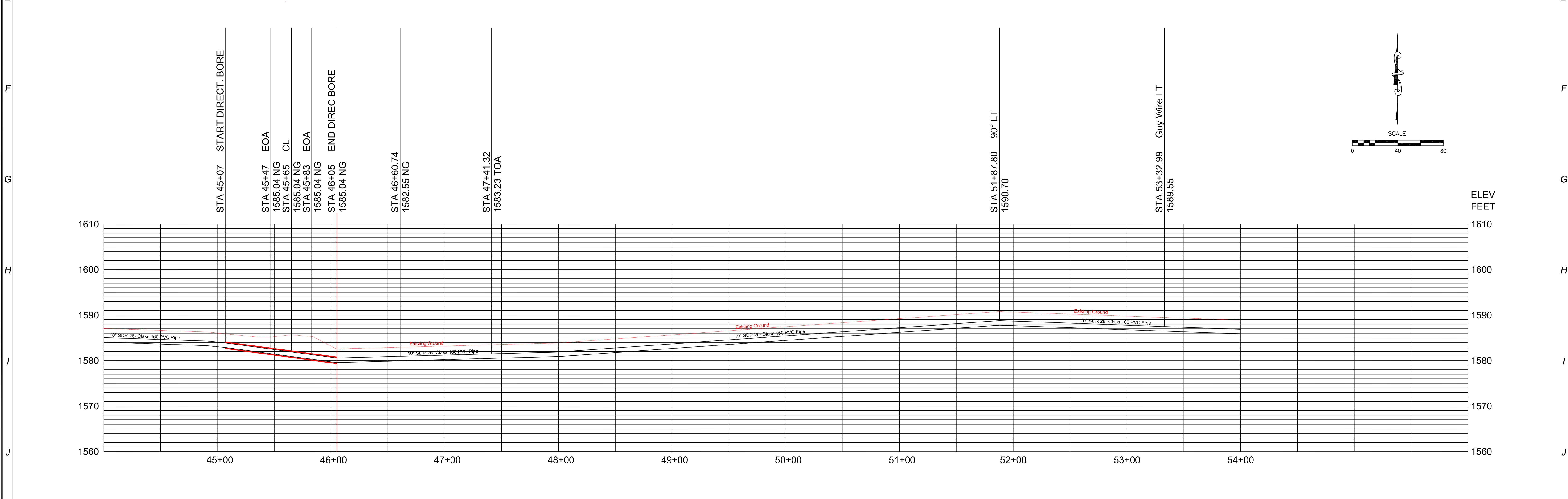
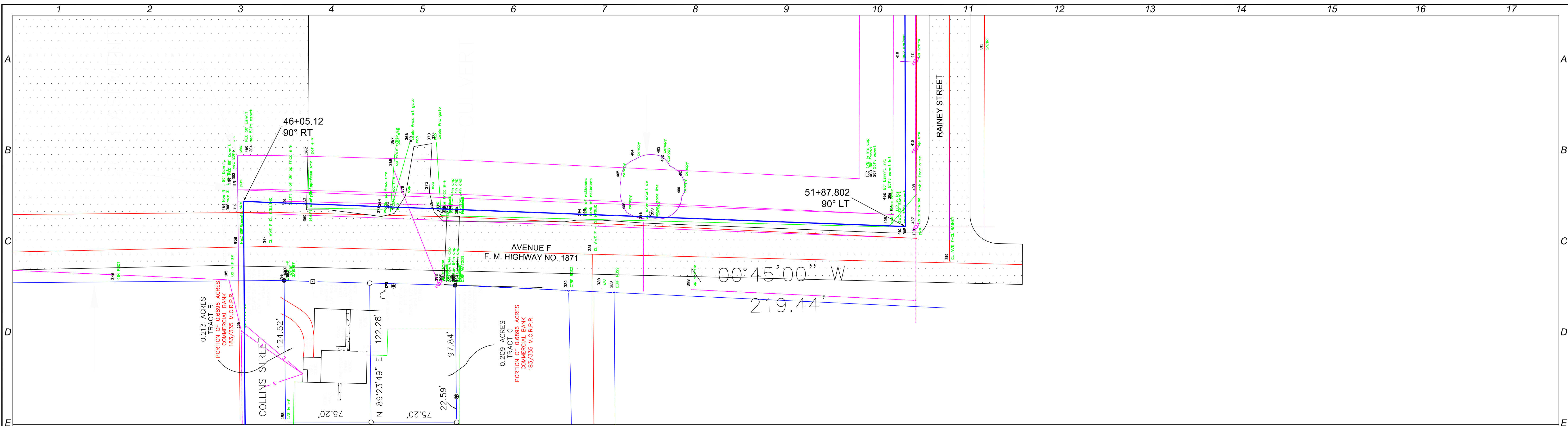

REFERENCE DRAWINGS	NOTES	NO.	REVISIONS	BY	CHK.	DATE	APPR.		BLACKWELL ENVIRONMENTAL, LLC 1107 Highway 1431 - #113 - Marble Falls, Texas 78654 (512) 247-8700 Voice - (512) 56-8489 FAX	CITY OF MASON, TEXAS WATER SYSTEM IMPROVEMENTS - PHASE 1 PROPOSED 10" WATER LINE P&P ALIGNMENT SHEET STA 45+00 to 54+00
							DRAWN: 11-10-08 CHECKED: 11-10-08 APPROVED: BNC (Owner) DATE: 11-10-08			

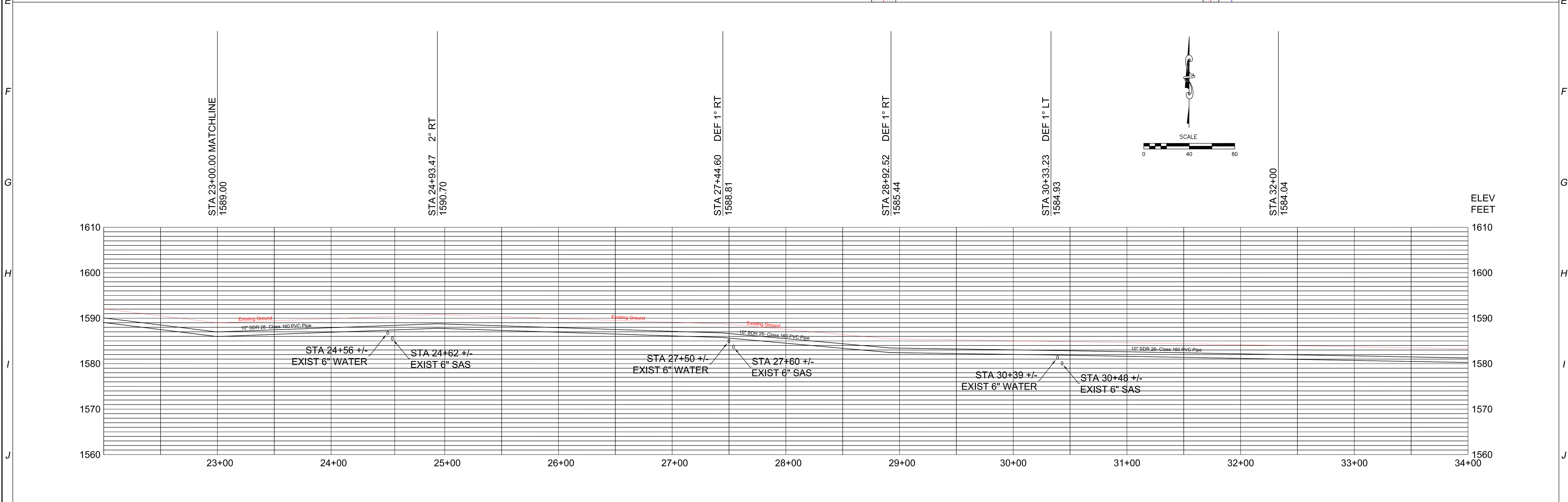
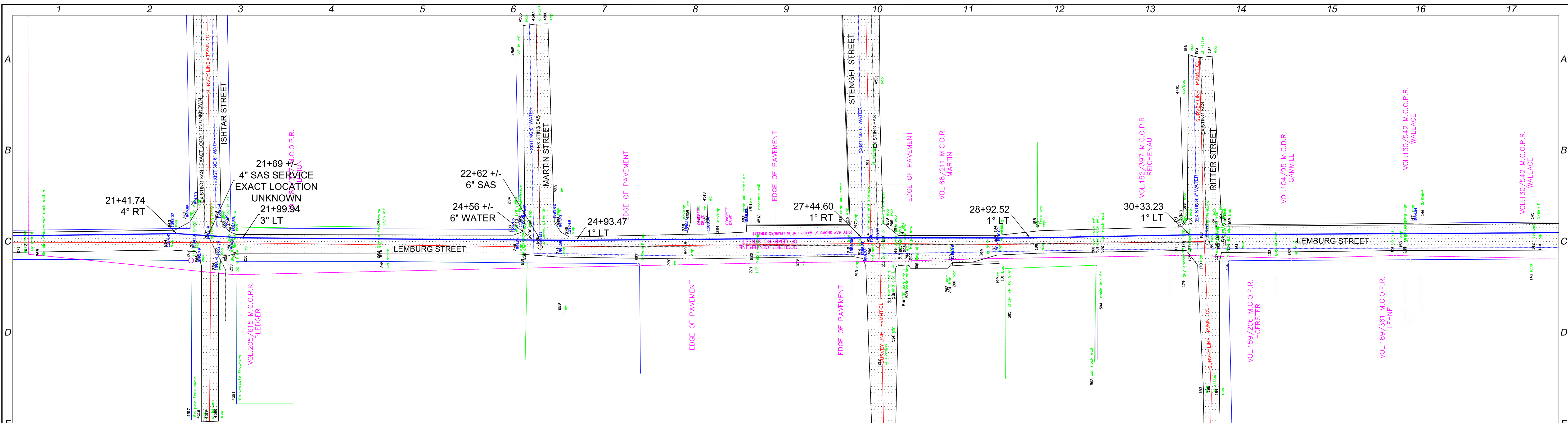

REFERENCE DRAWINGS	NOTES	NO.	REVISIONS	BY	CHK.	DATE	APPR.			CITY OF MASON, TEXAS WATER SYSTEM IMPROVEMENTS - PHASE 1 PROPOSED 10" WATER LINE P&P ALIGNMENT SHEET STA23+00 to 34+00		JOB NO.	DRAWING NO.	9
							DATE							

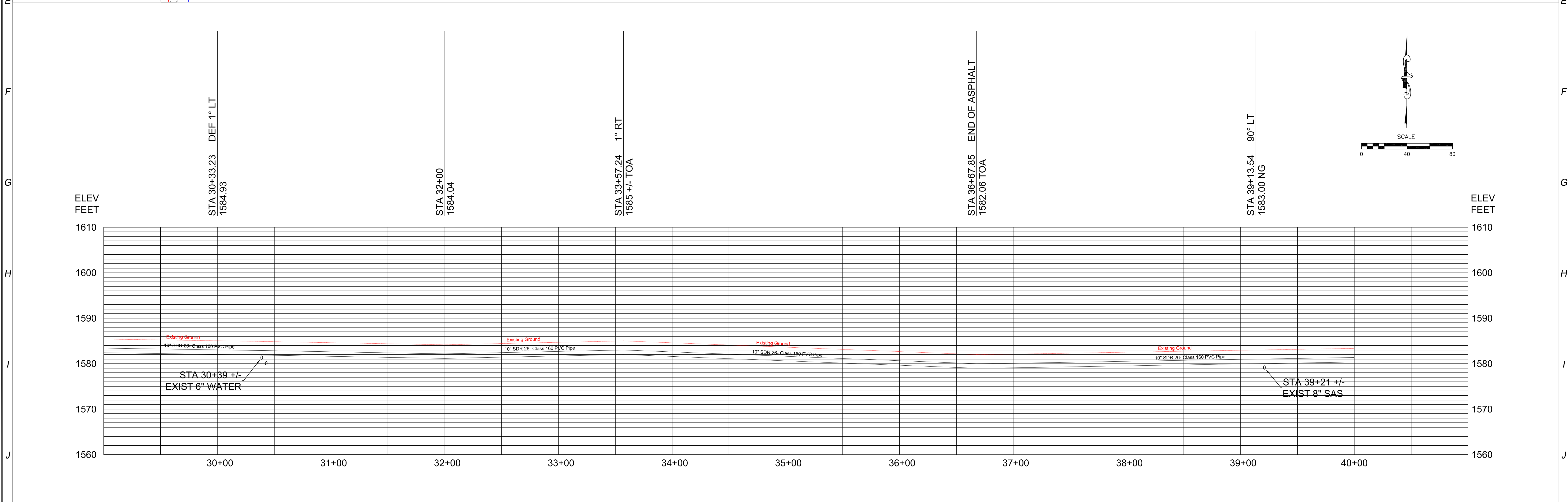
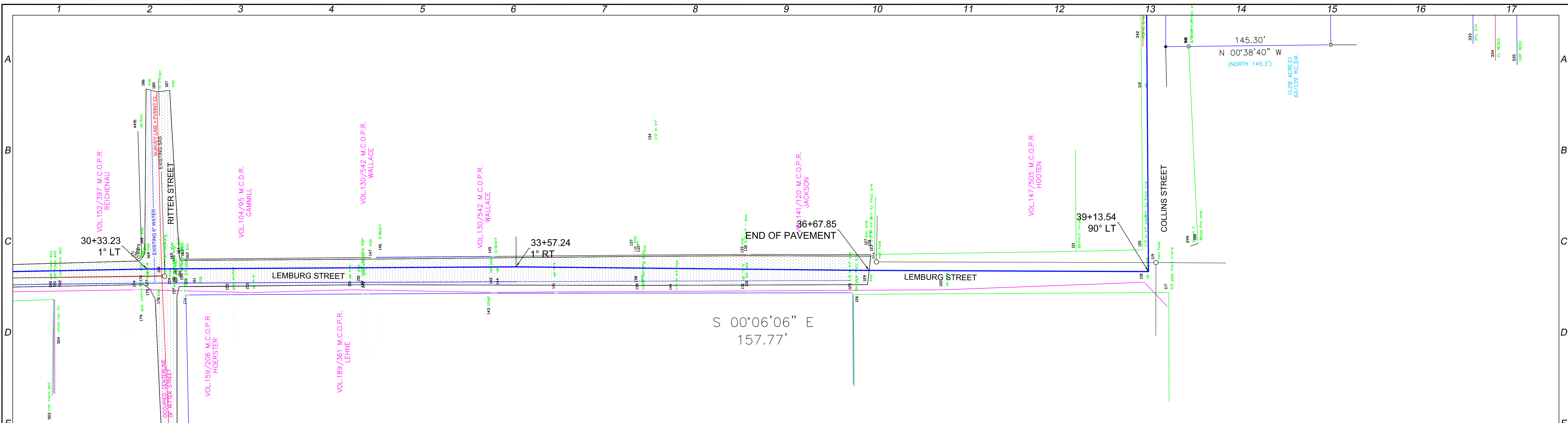

NO.	REVISIONS	BY	CHK.	DATE	APPR.

REFERENCE DRAWINGS

NOTES

STATE OF TEXAS

61679

JAMES E. BLACKWELL

REGISTERED PROFESSIONAL ENGINEER

The seal appearing on this document was authorized by James E. Blackwell, P.E. 61679 on November 10, 2008.

BLACKWELL ENVIRONMENTAL, LLC

1107 Highway 1431 - #113 - Marble Falls, Texas 78654
(512) 247-8700 Voice - (512) 56-8489 FAX

DRAWN	CHECKED	APPROVED	
		BNC	OWNER
DATE	DATE	SCALE	
11-10-08	11-10-08	0 40 80	

CITY OF MASON, TEXAS

WATER SYSTEM IMPROVEMENTS - PHASE 1

PROPOSED 10" WATER LINE

P&P ALIGNMENT SHEET

STA 30+00 to 40+00

JOB NO.	DRAWING NO.	10 / 13
---------	-------------	---------

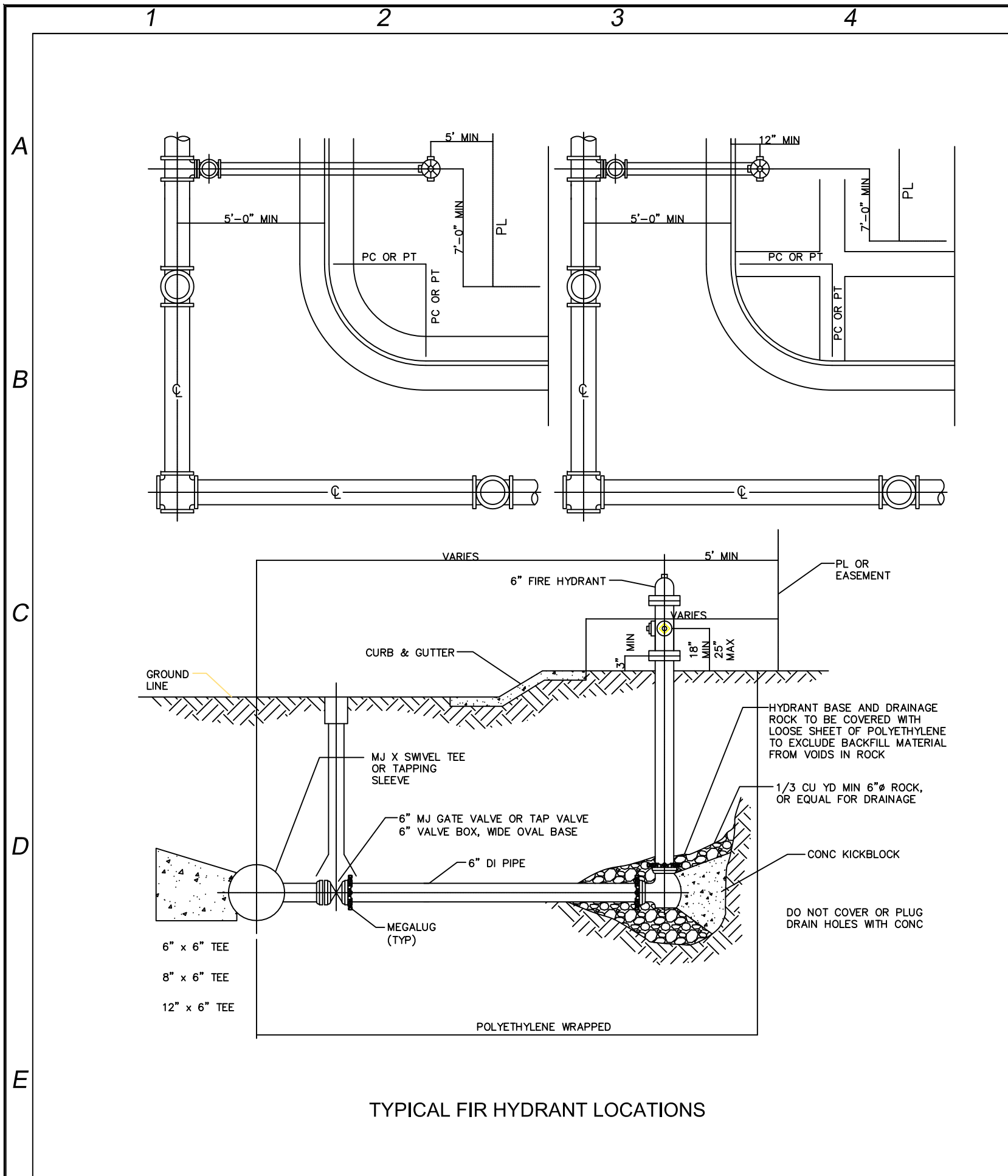

TYPICAL FIRE HYDRANT LOCATIONS

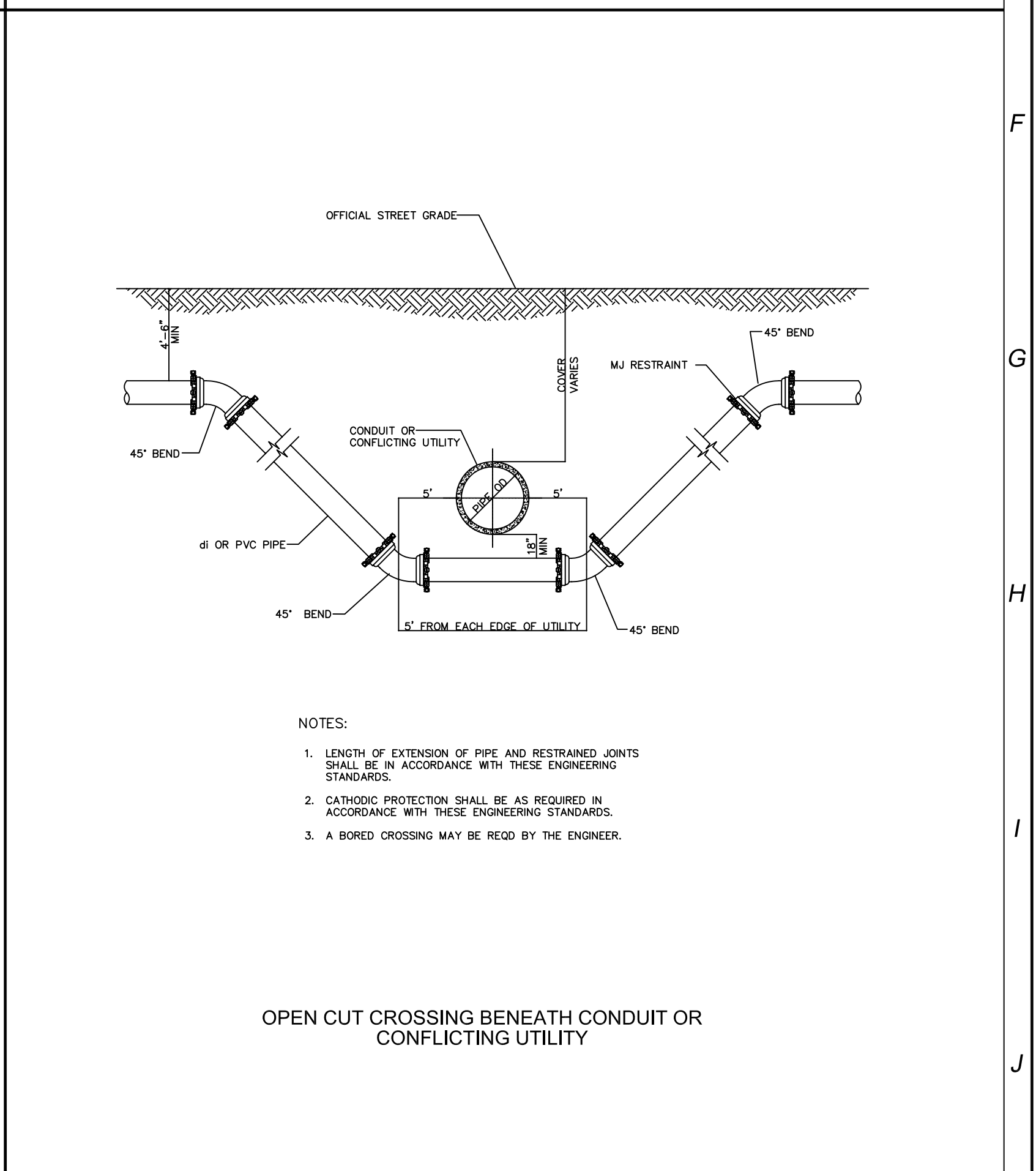
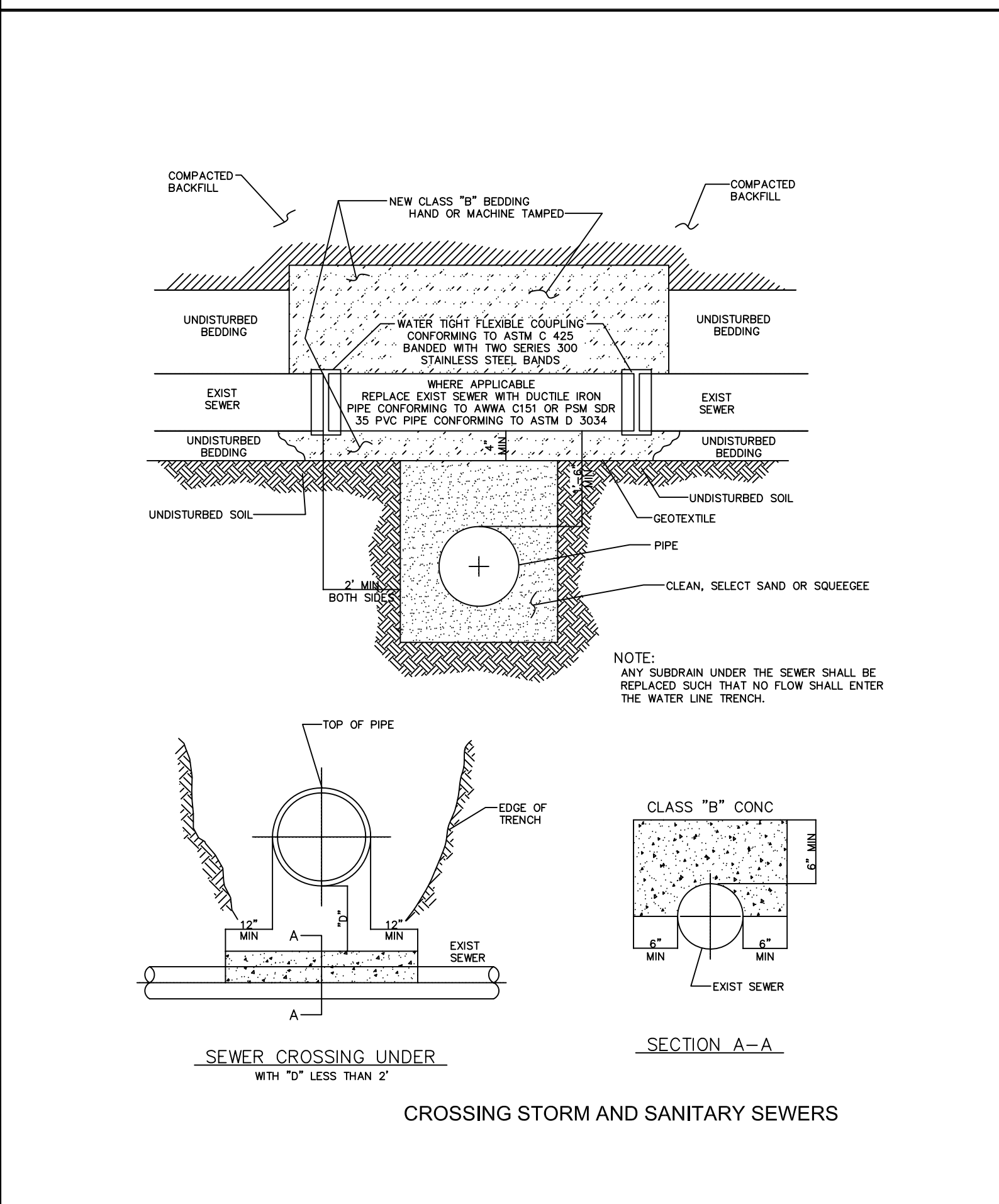
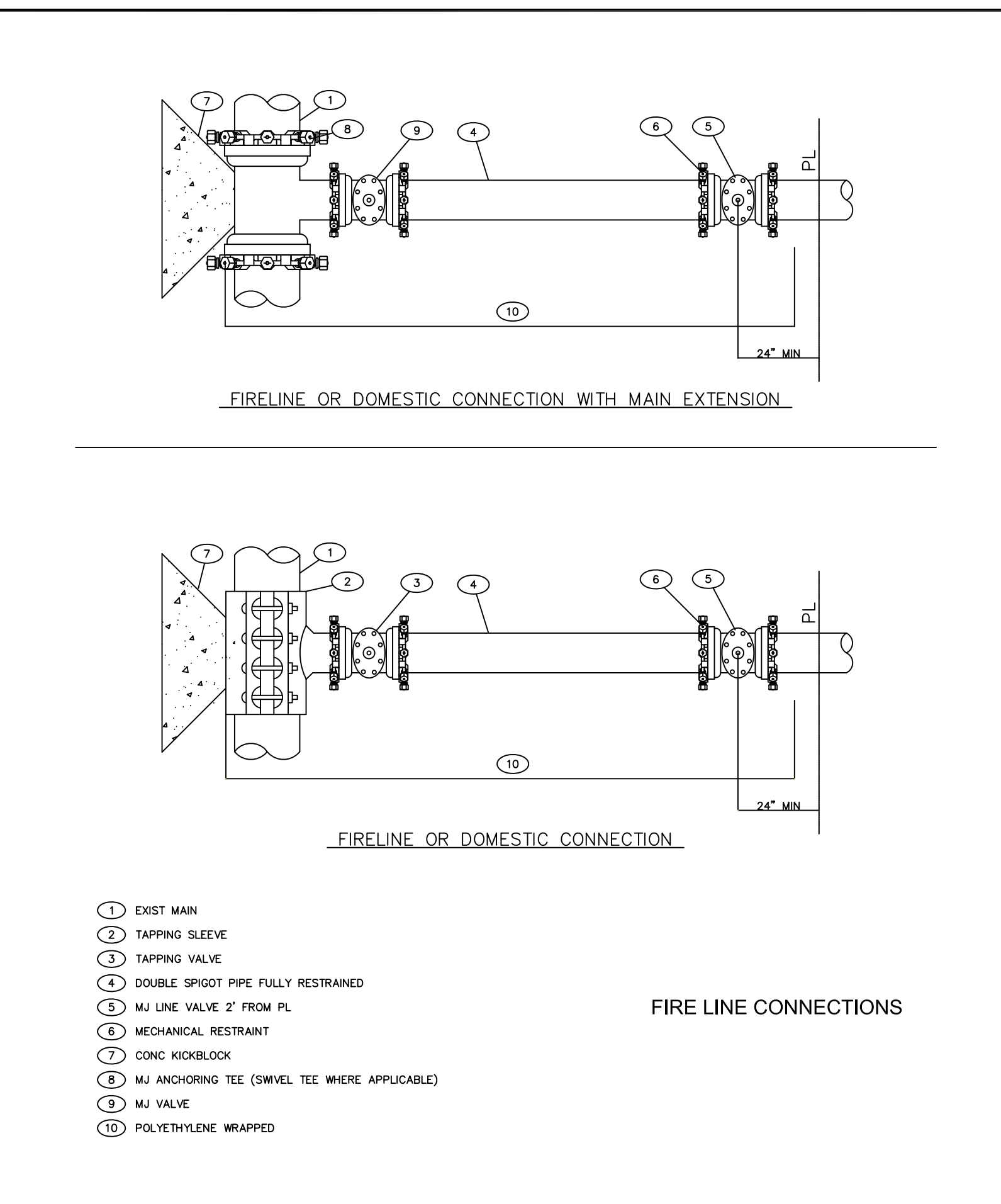
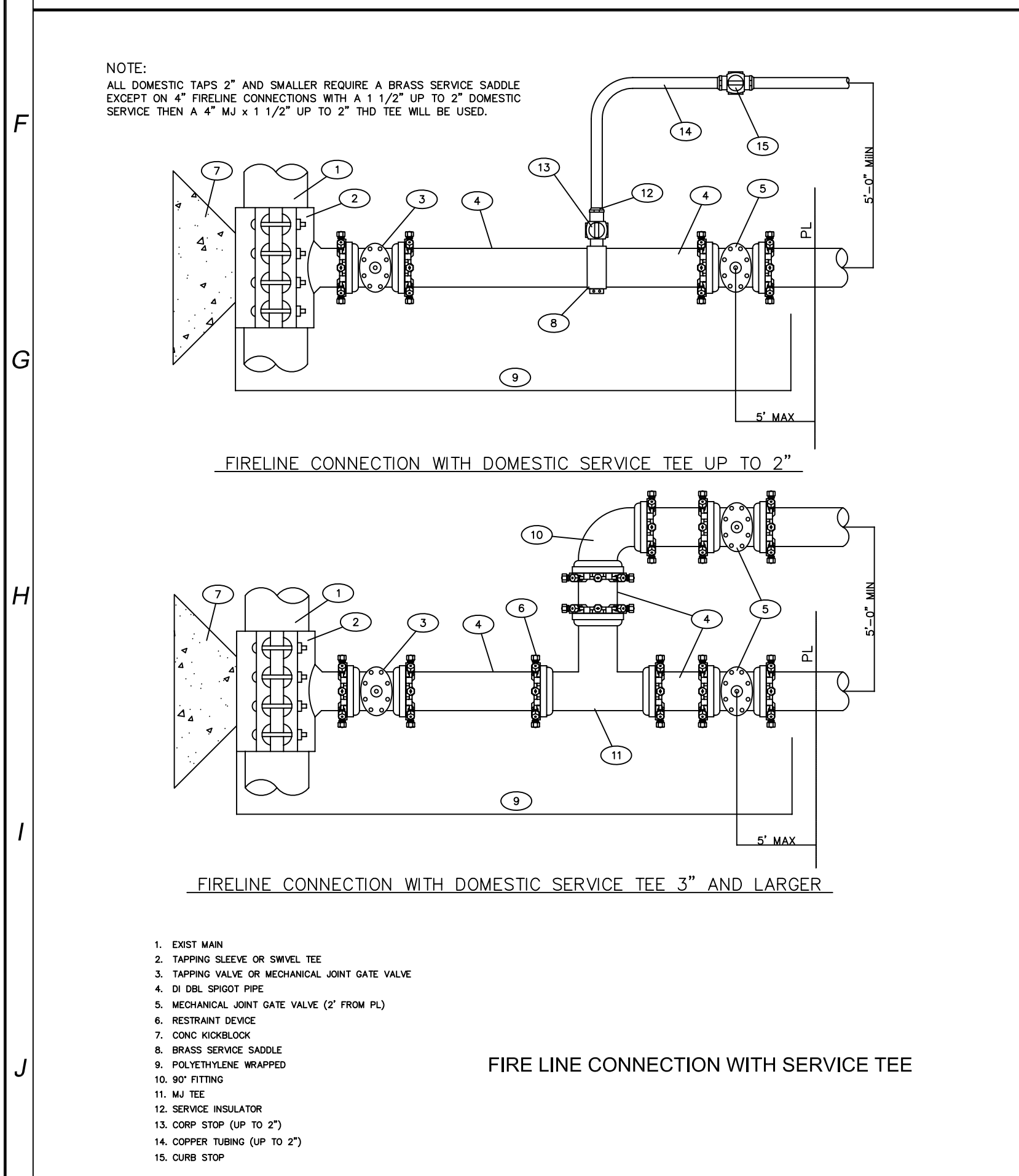
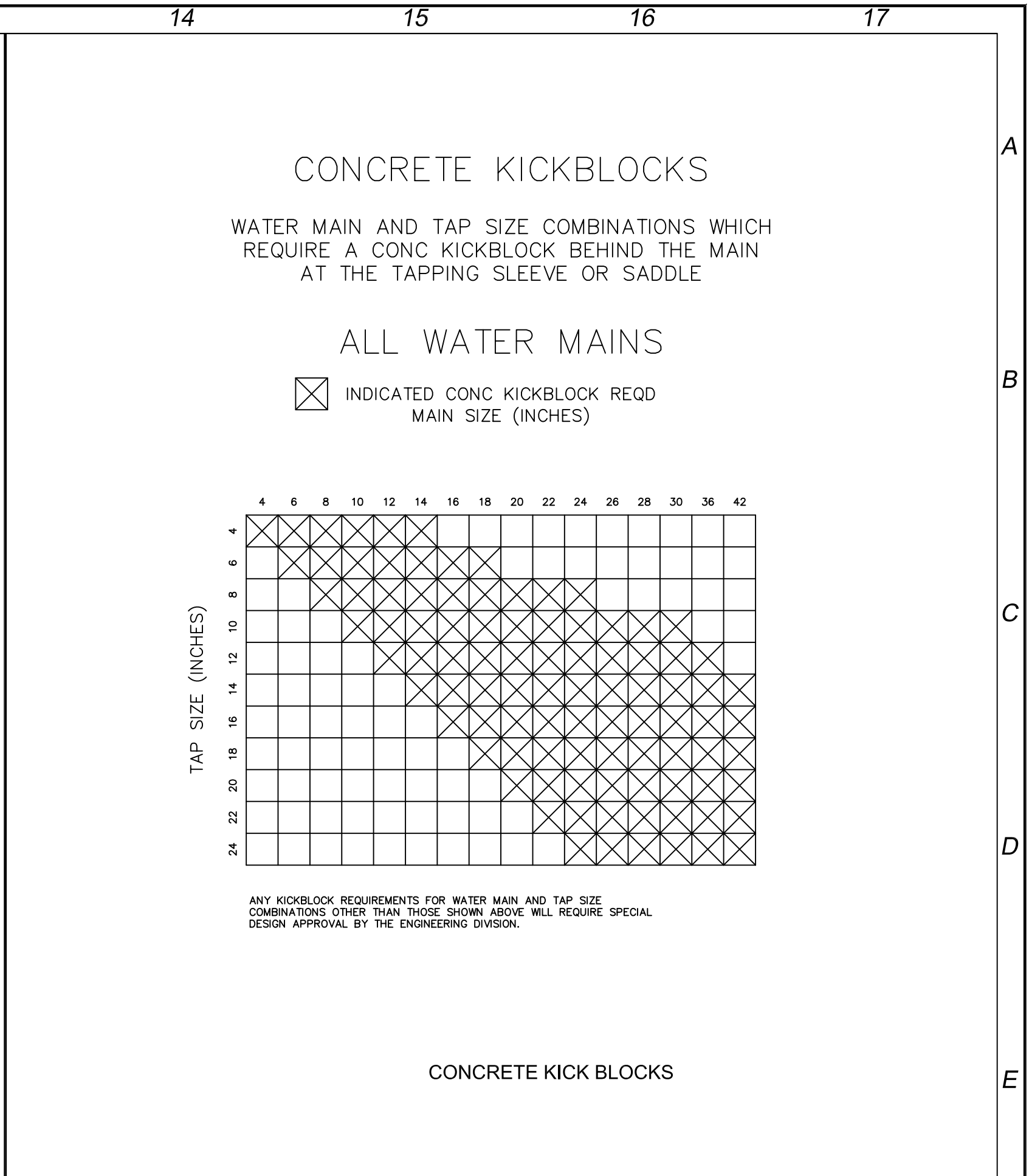
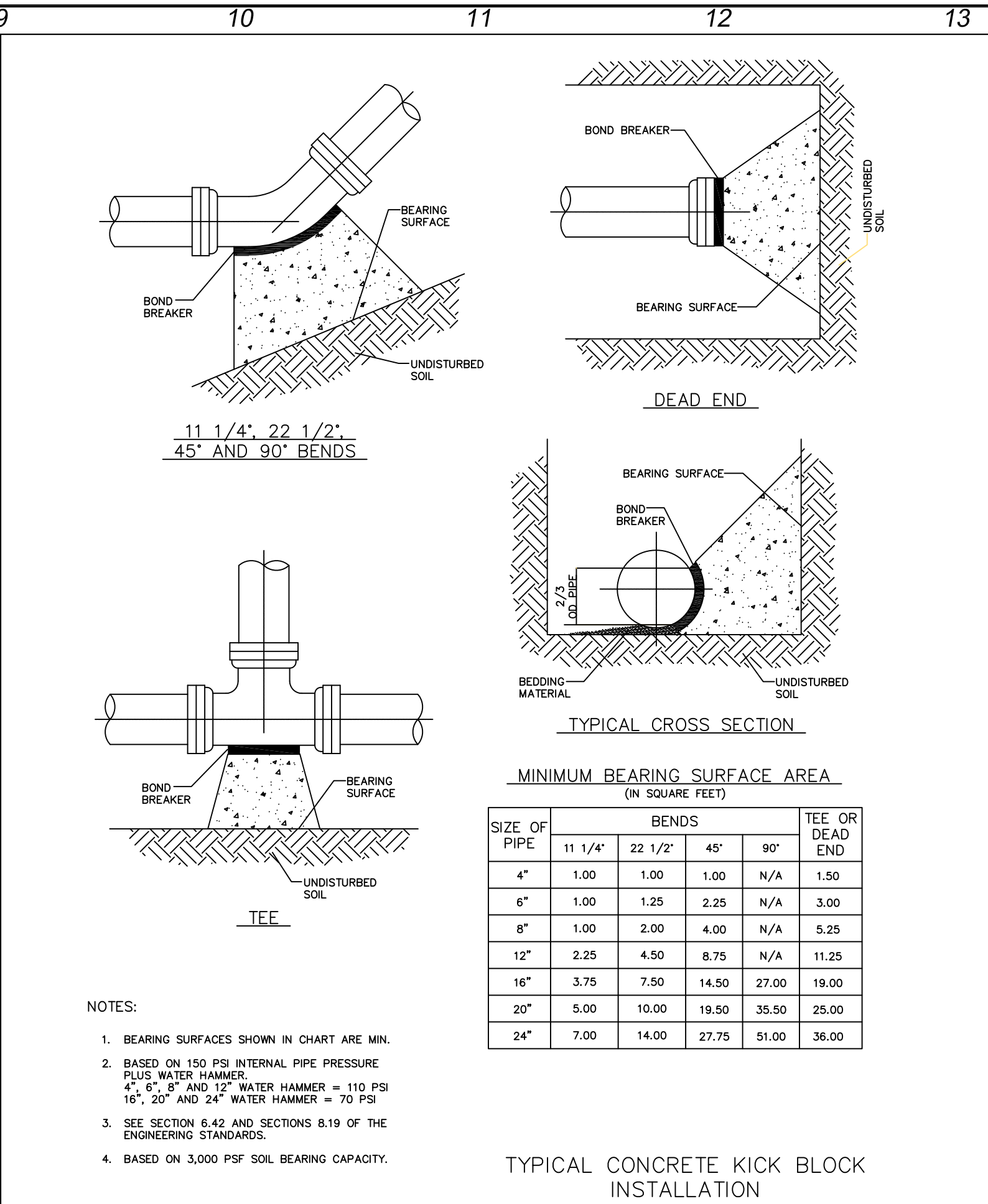
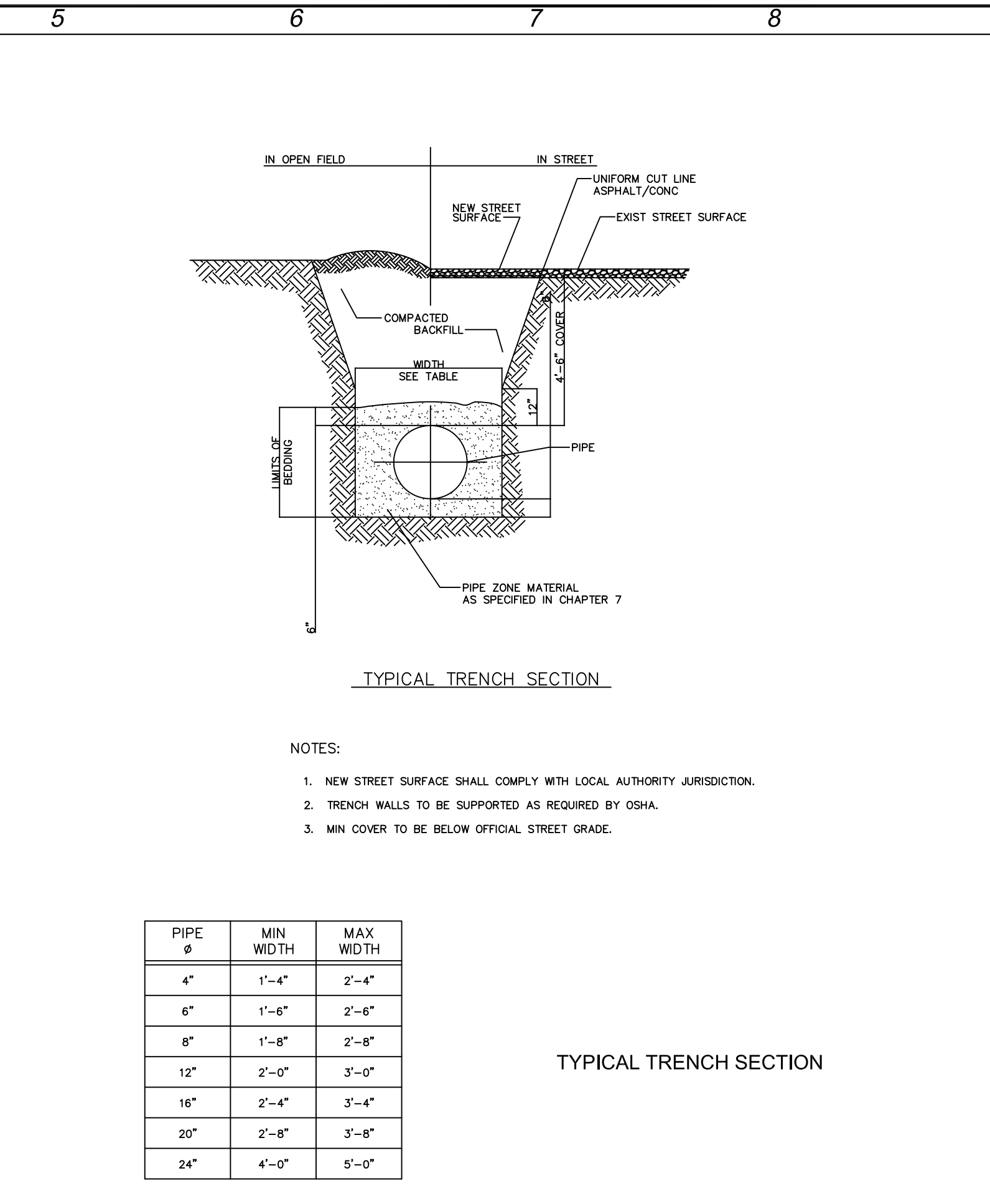

REFERENCE DRAWINGS

NOTES

NO.	REVISIONS	BY	CHK.	DATE	APPR.

STATE OF TEXAS

JAMES E. BLACKWELL

61679

REGISTERED PROFESSIONAL ENGINEER

The seal appearing on this document was authorized by James E. Blackwell, P.E. 61679 on November 10, 2008.

BLACKWELL ENVIRONMENTAL, LLC

1107 Highway 1431 - #113 - Marble Falls, Texas 78654
(512) 247-8700 Voice - (512) 56-8489 FAX

DRAWN	CHECKED	APPROVED	
		BNC	OWNER
DATE	DATE		
11-10-08	11-10-08		

CITY OF MASON, TEXAS

WATER SYSTEM IMPROVEMENTS - PHASE 1

PROPOSED 10" WATER LINE

STANDARD DETAIL SHEET #1

JOB NO. DRAWING NO.

12 13

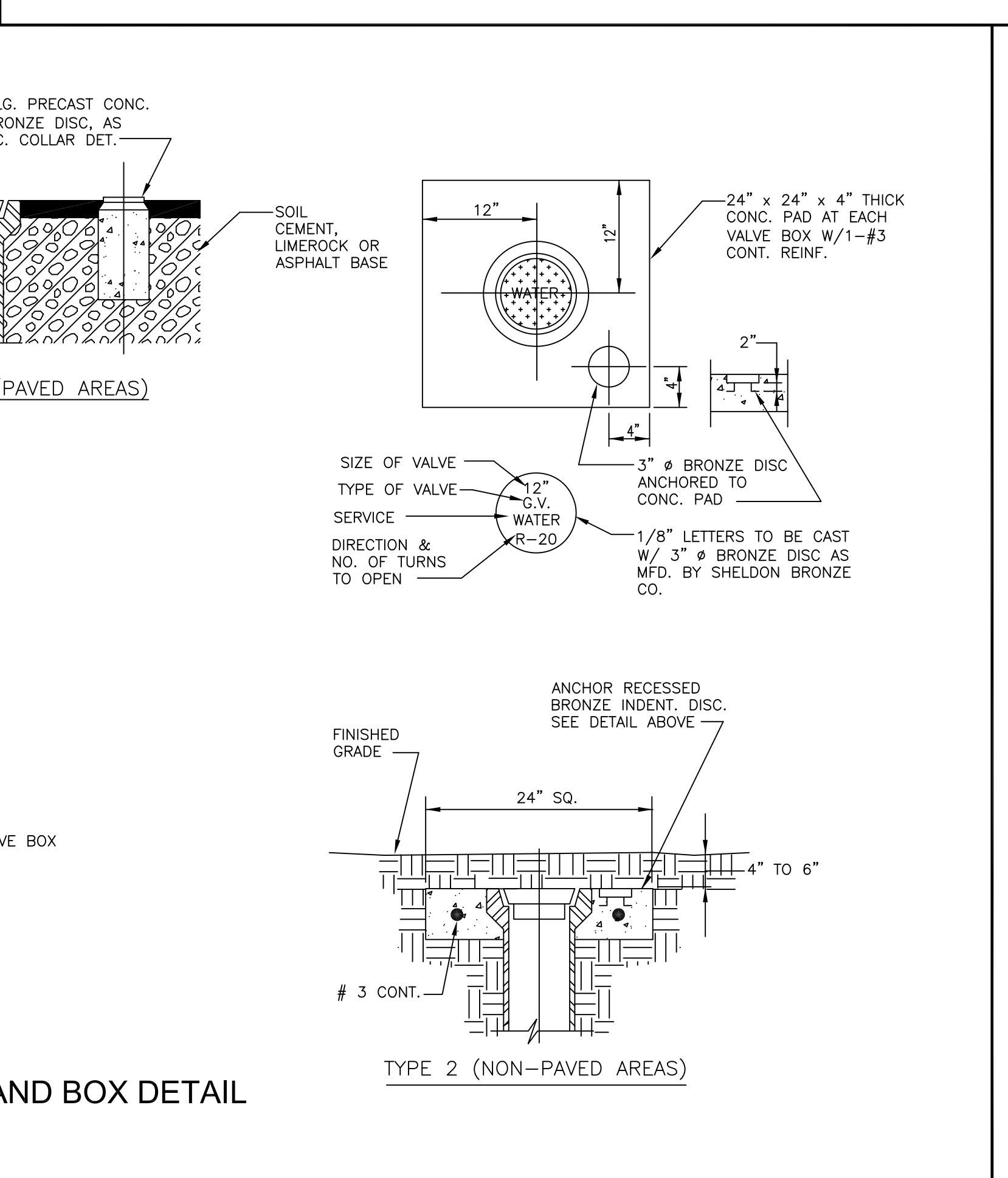
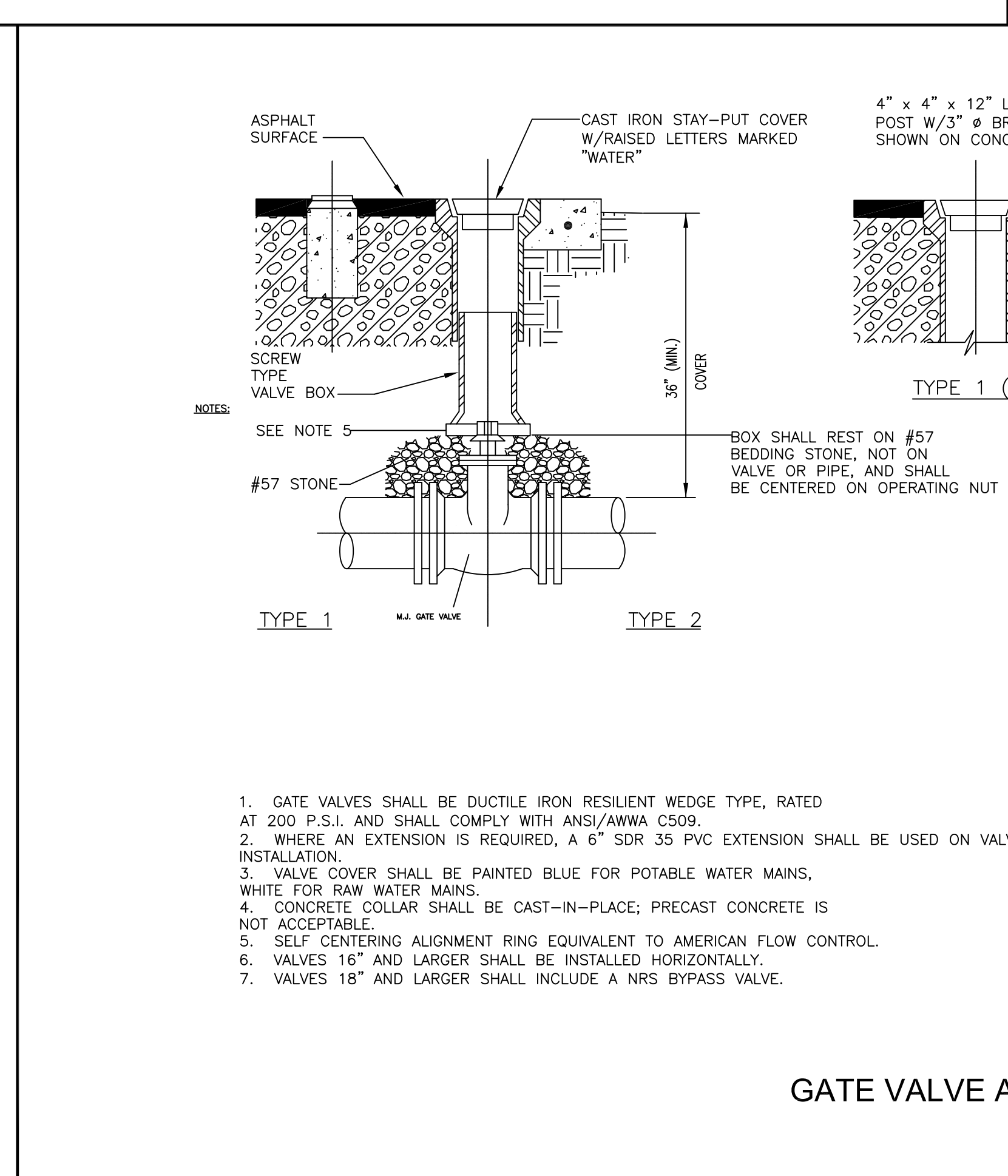
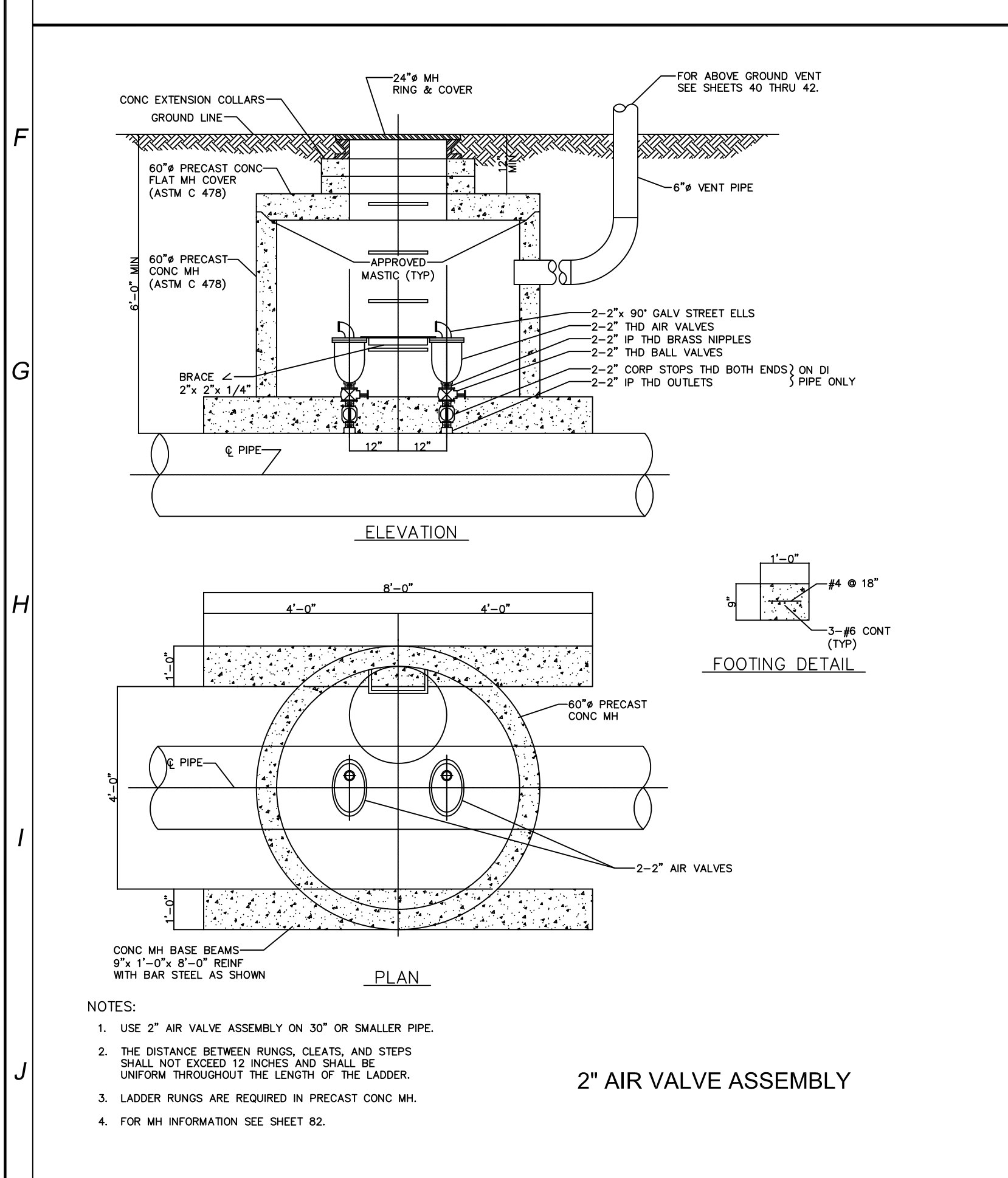
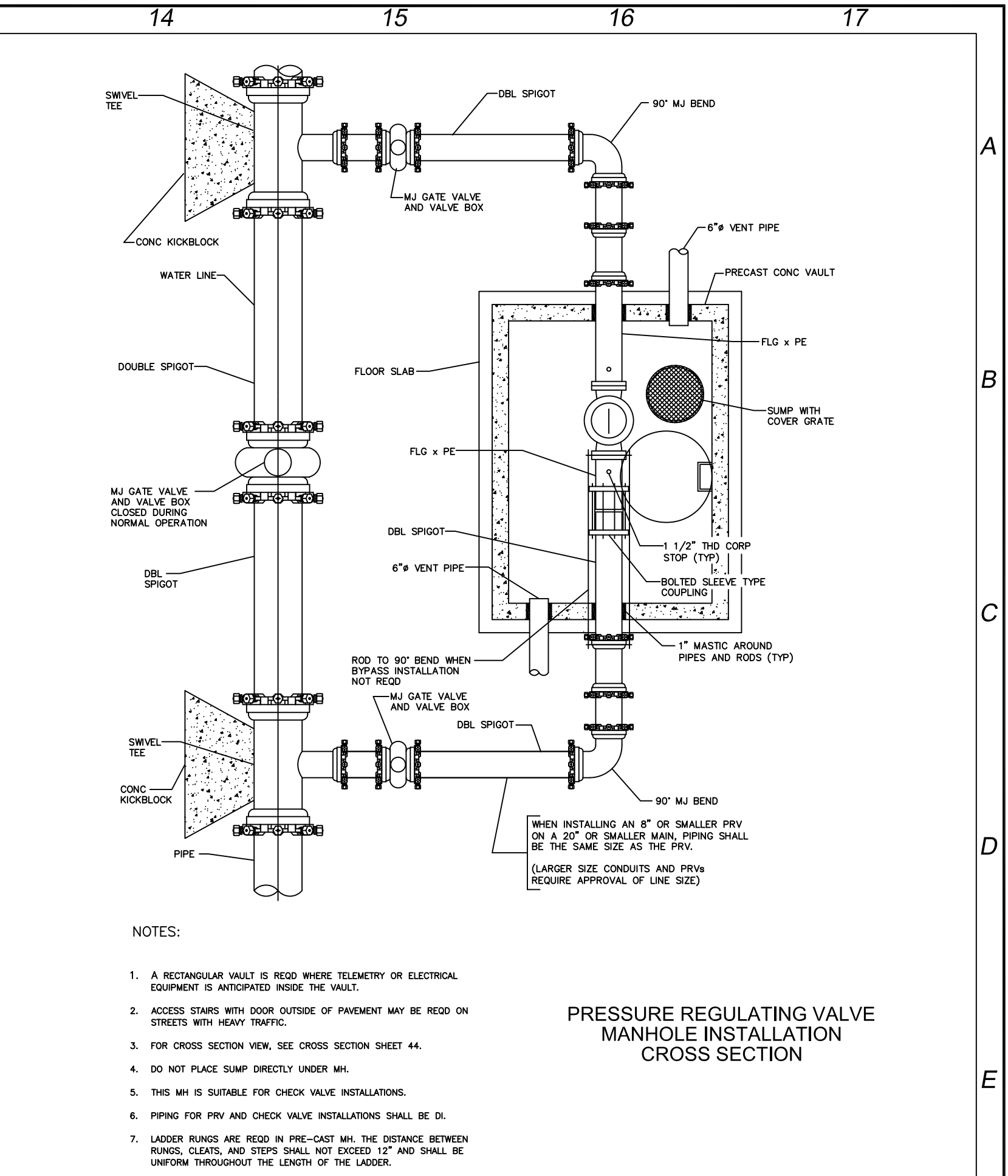
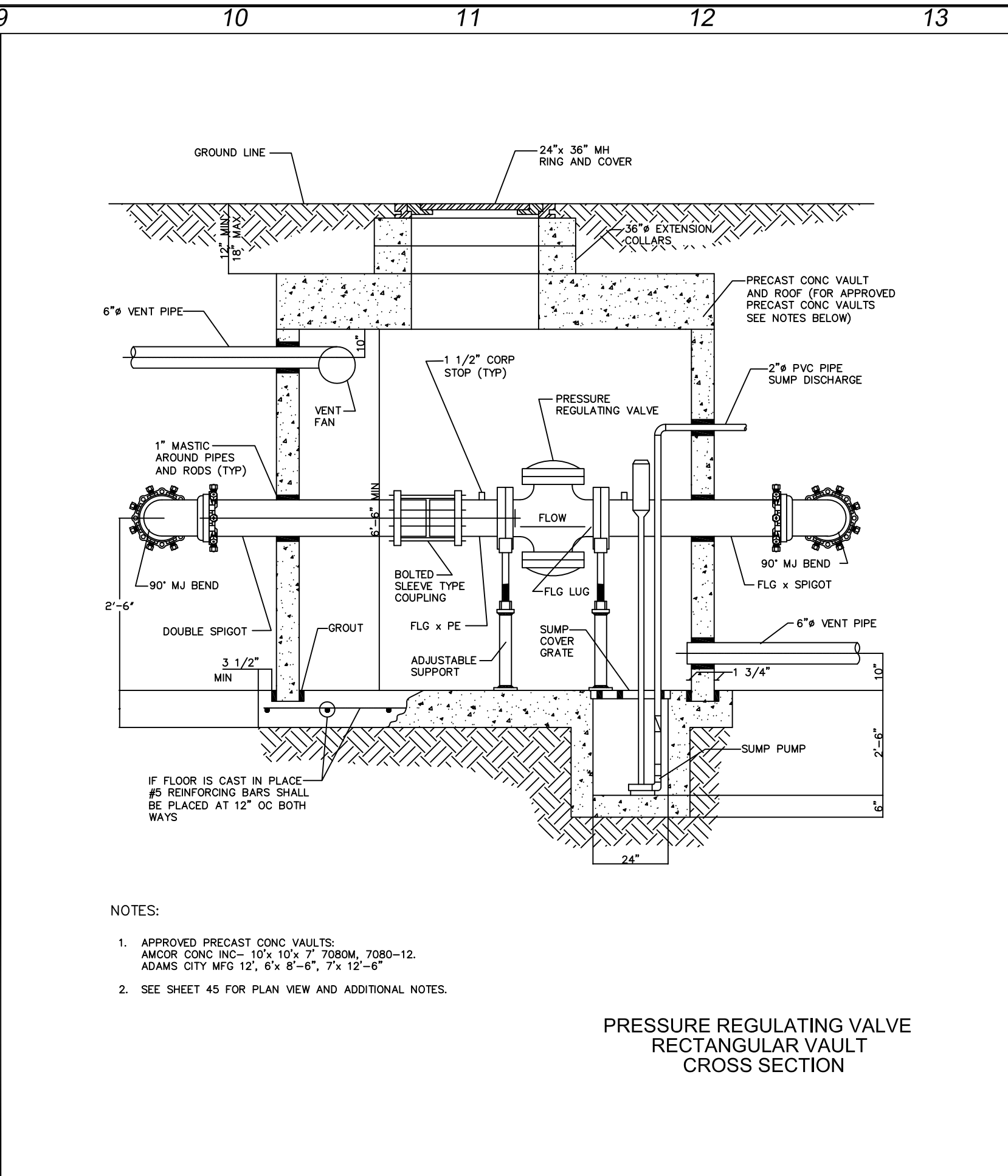
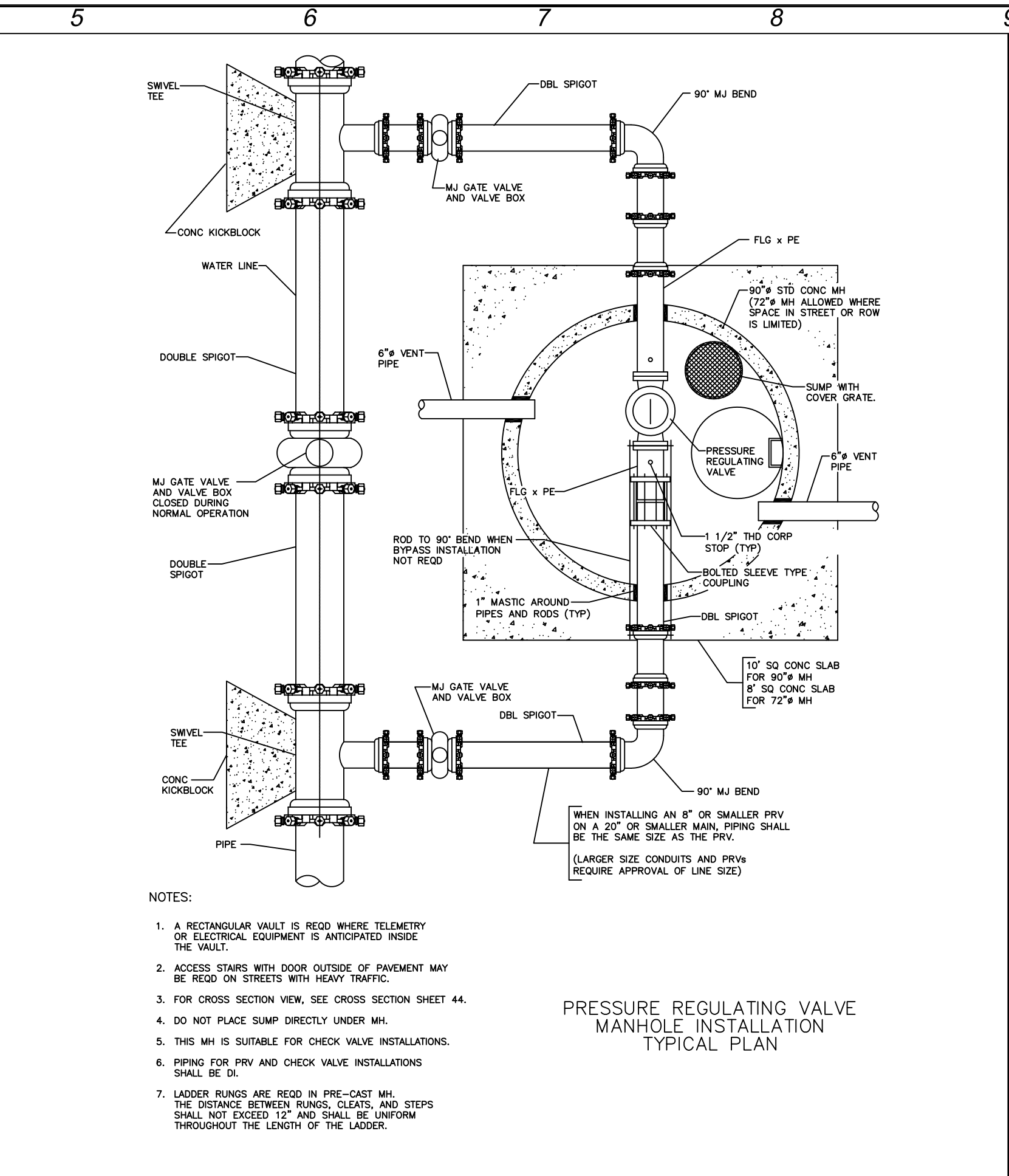
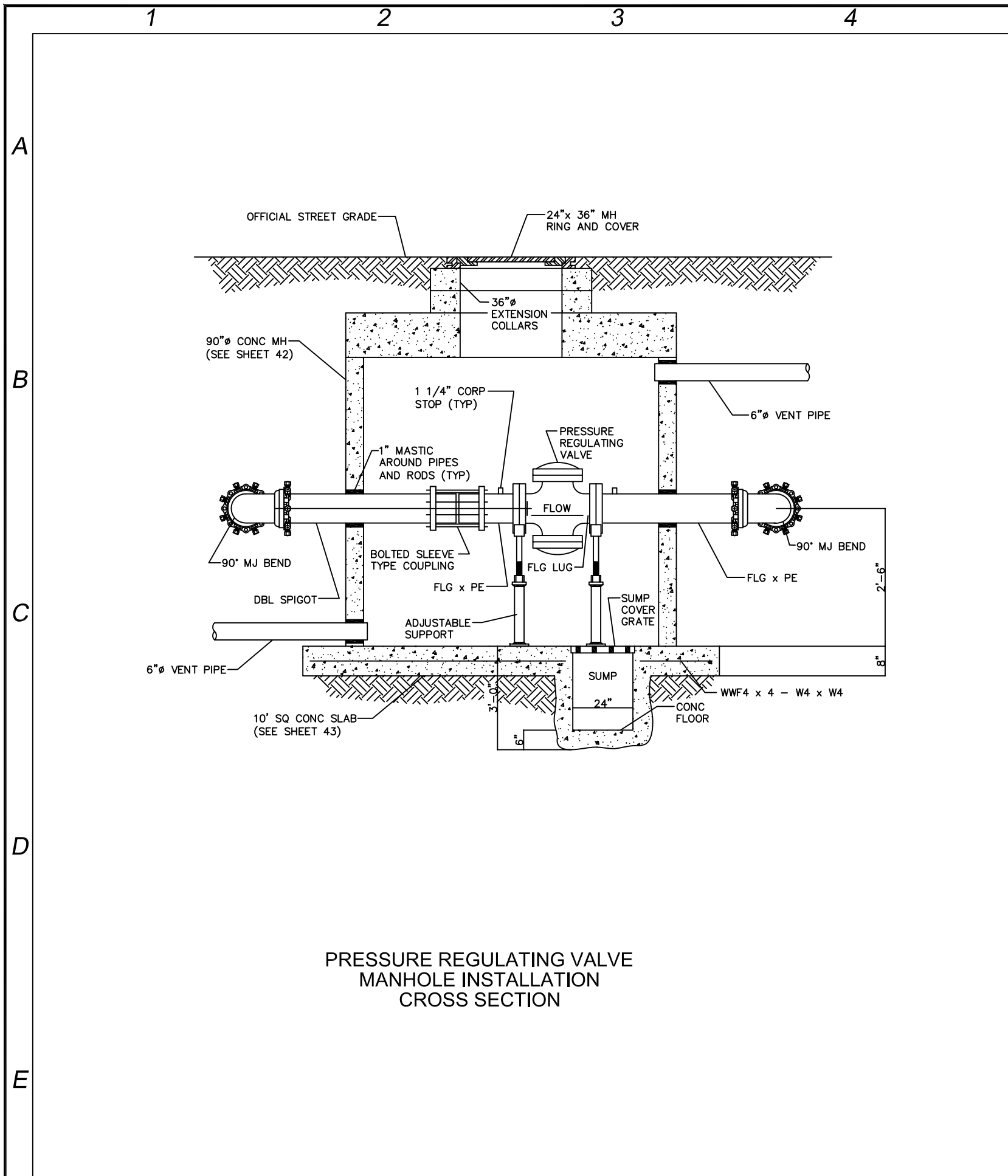

REFERENCE DRAWINGS	NOTES
1	1. USE 2" AIR VALVE ASSEMBLY ON 30" OR SMALLER PIPE.
2	2. THE DISTANCE BETWEEN RUNGS, CLEATS, AND STEPS SHALL NOT EXCEED 12 INCHES AND SHALL BE UNIFORM THROUGHOUT THE LENGTH OF THE LADDER.
3	3. LADDER RUNGS ARE REQUIRED IN PRECAST CONC MH.
4	4. FOR MH INFORMATION SEE SHEET 82.

NO.	REVISIONS	BY	CHK.	DATE	APPR.

JAMES E. BLACKWELL
 REGISTERED PROFESSIONAL ENGINEER
 61679
 The seal appearing on this document was authorized by James E. Blackwell, P.E. 61679 on November 10, 2008.

BLACKWELL ENVIRONMENTAL, LLC
 1107 Highway 1431 - #113 - Marble Falls, Texas 78654
 (512) 247-8700 Voice - (512) 56-8489 FAX

DRAWN	CHECKED	APPROVED
DATE	DATE	BNC
11-10-08	11-10-08	OWNER

CITY OF MASON, TEXAS
WATER SYSTEM IMPROVEMENTS - PHASE 1
PROPOSED 10" WATER LINE
STANDARD DETAIL SHEET #2

JOB NO.	DRAWING NO.